

## OVERHEAD LIGHT & OVERHEAD ARMS

Item Numbers 8500, 8504, 8505, 8510, 8512, 8514, 8516, 8518, 8538

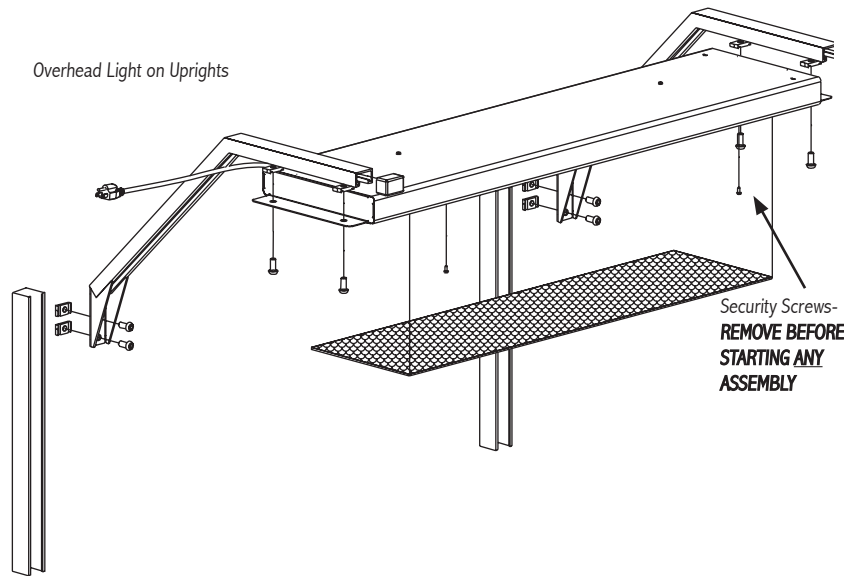
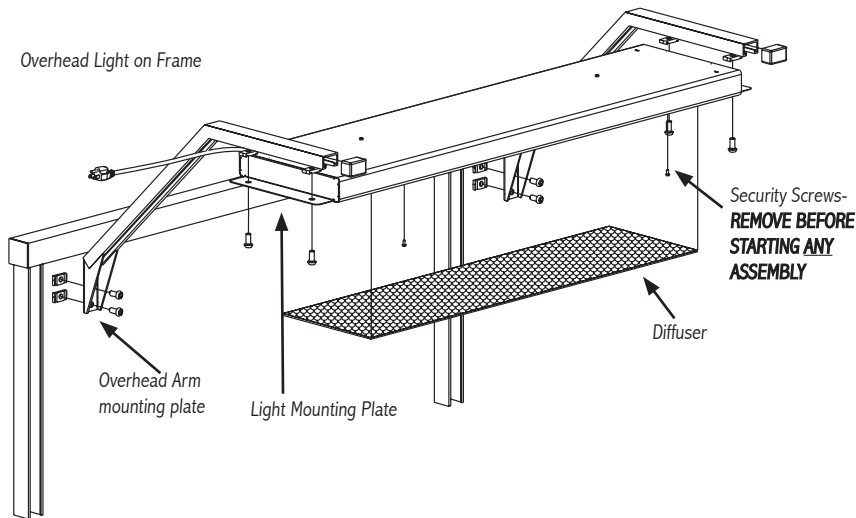

## ACCESSORIES

PARTS AND HARDWARE	QUANTITY
Overhead Arms	2
End Caps	2
Basic Bolts	4 (Arms only) 8 (With light)
Basic Nuts	4 (Arms only) 8 (With light)
Light Unit	1
7/32 Allen Wrench	1
<b>Other Items Needed (not included)</b>	
24" T8 bulb for 36"	3
36" T8 bulb for 48"	3
48" T8 bulb for 60" & 72"	3
Phillips head screwdriver	
Tape Measure	

• **Note: To install Overhead Arms only, perform steps 3 & 4.**

1. **Unscrew 2 security screws on face of light unit.** Remove plastic diffuser.
2. Insert T8 light bulbs into fixture. Plug light in to test correct installation of bulbs. Replace diffuser and security screws.
3. Insert two (2) Basic Bolts into mounting plate on Overhead Arm. Secure with Basic Nut with grooves facing the back of the mounting plate. Turn only one revolution. Repeat for other Overhead Arm.
4. Insert Basic Nuts attached to Overhead Arm mounting plate into frame channel of workstation or Uprights and turn Basic Bolt 90 degrees clockwise to grip. Top of mounting plate should be flush with top of frame cross member. Tighten the bolts. Repeat for other Overhead Arm.
5. Insert 4 Basic Bolts from bottom into light mounting plate. Secure with 4 Basic Nuts with grooves facing down. Turn only one revolution.
6. Position light unit with cord facing the frame. Insert Basic Nuts attached to light unit into Overhead Arm channel and turn Basic Bolt 90 degrees clockwise to grip.
7. Slide the light unit to the desired position. Tighten the bolts. Slide End Caps onto front ends of Overhead Arms.